

PARTS LIST			
ITEM	QTY	PART NUMBER	DESCRIPTION
1	8	M3x8mm Pan	Front/Rear Panel Screws
2	8	M4x16mm CSK	Bezel Assembly Screws
3	2	M3x6mm CSK	Base Panel Screws
4	8	M6420000	Clip for Trims
5	4	M6420105	Technofeet
6	1	M6402525	Wrap Around Cover
7	1	M6403355	Base/Internal Sides Sub-Assy
8	1	M6403455	Rear Panel 1.5 mm Thick
9	2	M6401055	Front/Rear Bezel
10	2	M6400057	Front Trim
11	2	M6400077	Rear Trim
12	2	AS054231	Bail Arm Kit
13	1	M6404275	Handle Bar

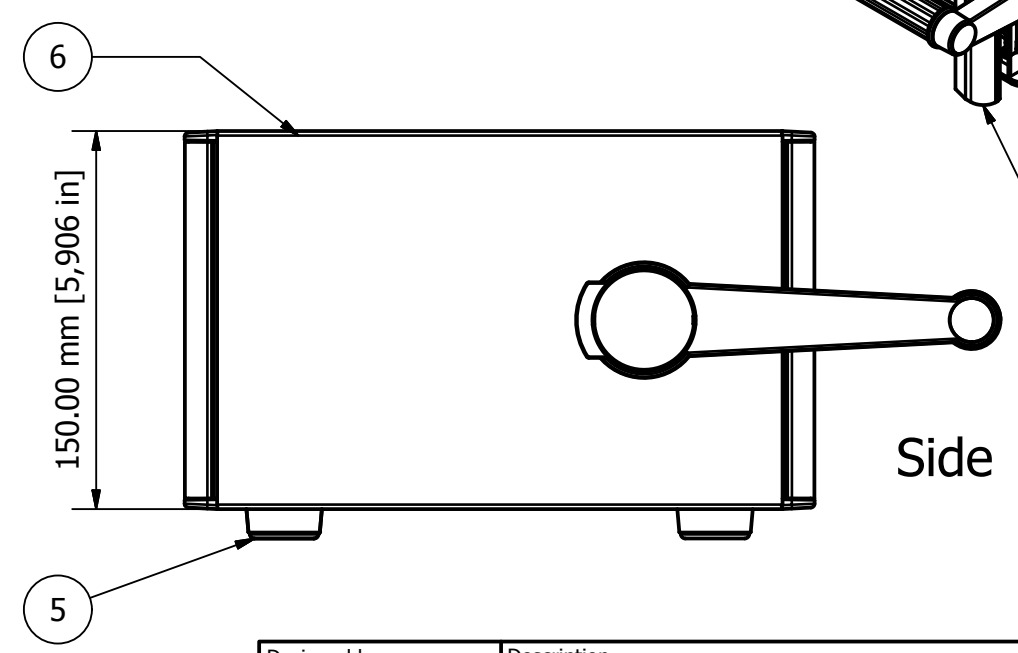
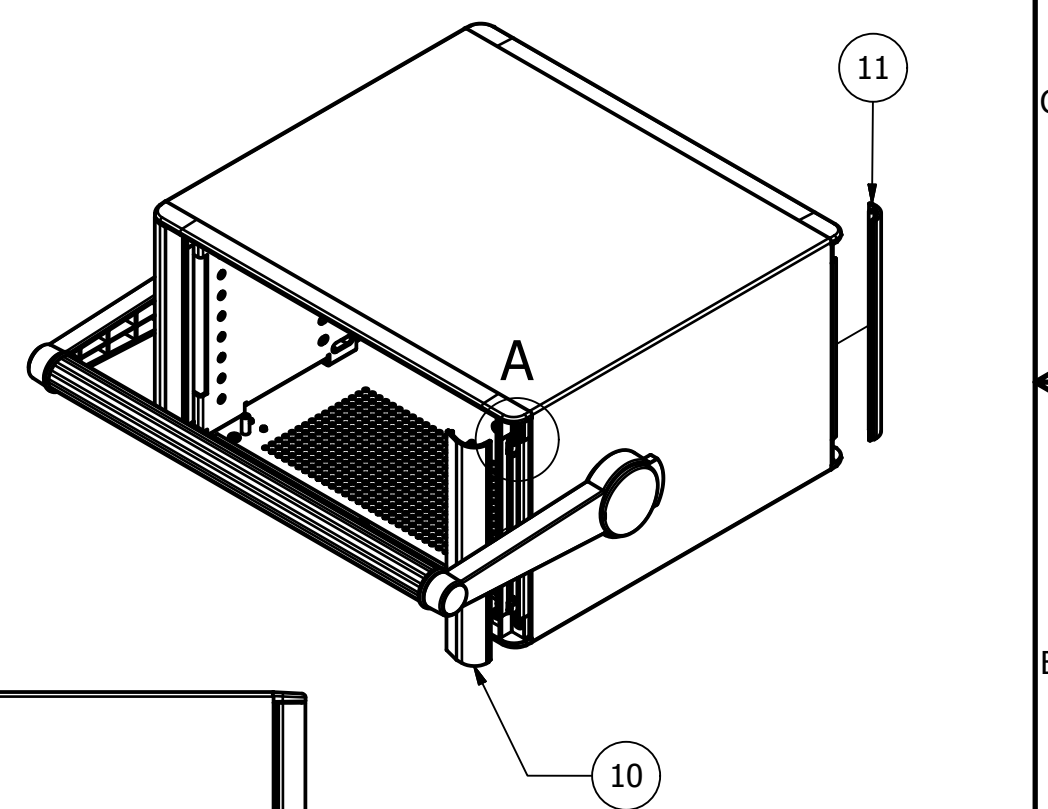

Front panel (M6400704) sold seperately

FIRST ANGLE PROJECTION

Designed by L Clark	Description Technomet R215H - Light Grey RAL 7035	Date 18/10/2016	Scale 1:3
METCASE ENCLOSURES 15 Brunel Way, Segensworth East, Fareham, Hampshire, PO15 5TX, UK. Tel: +44 (0)1489 583858 Email: sales@metcase.co.uk		METcase™ www.metcase.com Part Number M6427335	
		Issue 1	Sheet 1 / 2

© OKW Enclosures Ltd (Date as shown). This drawing contains proprietary information of OKW Enclosures Ltd and is tendered subject to the following conditions. The information be retained in confidence, not be reproduced or copied, and not be used or incorporated in any product, unless permission is obtained in writing from OKW Enclosures Ltd.

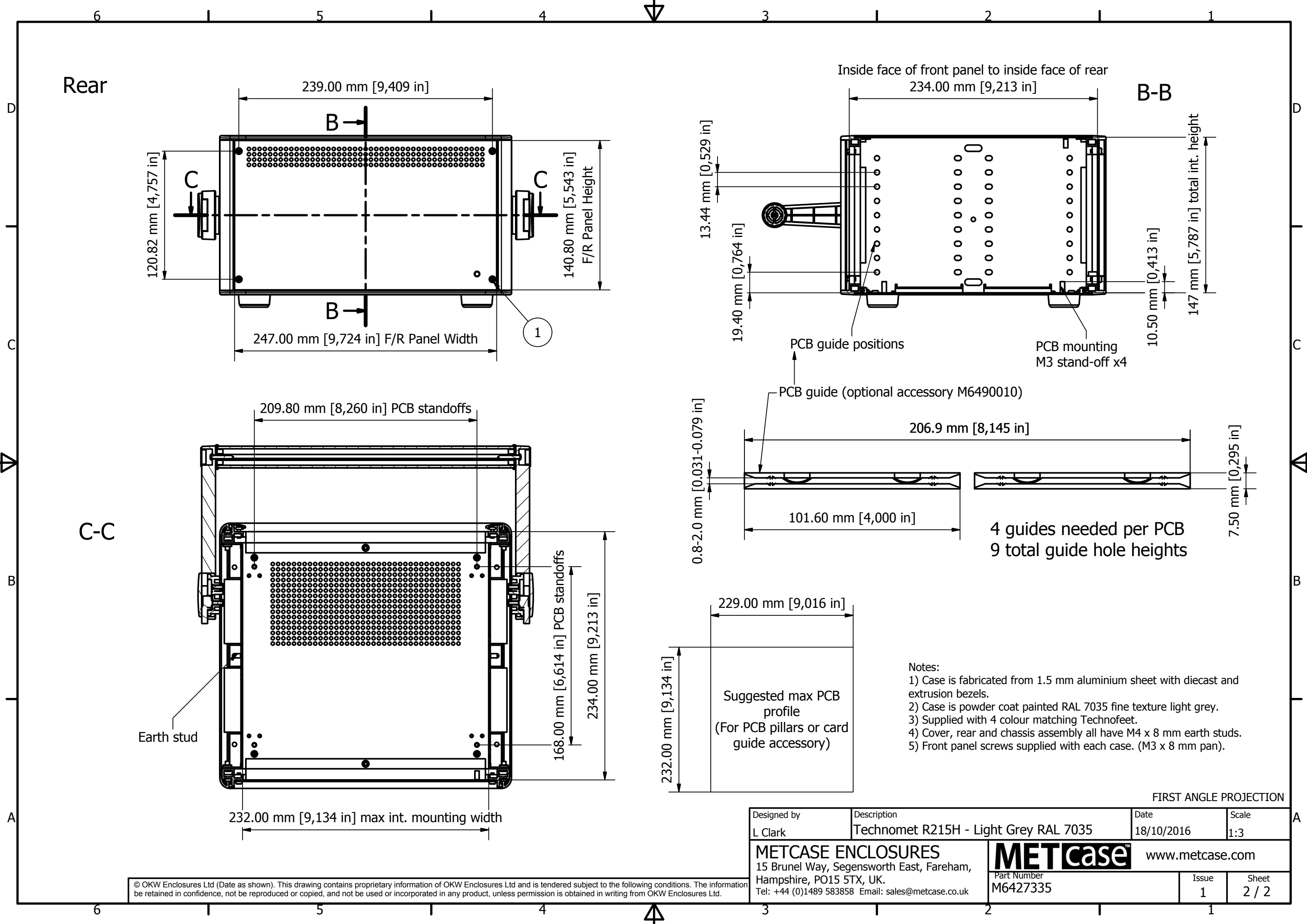

FIRST ANGLE PROJECTION

Designed by L Clark	Description Technomet R215H - Light Grey RAL 7035	Date 18/10/2016	Scale 1:3
METCASE ENCLOSURES 15 Brunel Way, Segensworth East, Fareham, Hampshire, PO15 5TX, UK. Tel: +44 (0)1489 583858 Email: sales@metcase.co.uk		METcase™ www.metcase.com Part Number M6427335	
		Issue 1	Sheet 2 / 2

© OKW Enclosures Ltd (Date as shown). This drawing contains proprietary information of OKW Enclosures Ltd and is tendered subject to the following conditions. The information be retained in confidence, not be reproduced or copied, and not be used or incorporated in any product, unless permission is obtained in writing from OKW Enclosures Ltd.